



PORTABLE CONTOURING MACHINE MASTER 3500

OPERATOR'S MANUAL
VER. 11/2007



▲ MS 3500 WITH
WATER SYSTEM
BASE PLATE

MS 3500 WITH
SLIDING WHEELS
BASE PLATE ▶



Dear client,

thank you very much for the trust you have shown in us by buying our **MASTER 3500**. We would like to provide you with some information as well as some advice about your new machine. All our machines, electrical conversion unit, etc, are designed and built according to EC norms and regulations, they are made to function perfectly and to last without causing you any problems; the quality is unsurpassable and all checks and controls are carried out with the utmost care. **MASTER 3500** is the result of both years of experience and technological innovations resulting in the creation of this highly professional product. This machine can achieve a high degree of productivity and quality which are up to the same standard as that of larger machines. Please use the instruction leaflet carefully and accurately to ensure excellent results. However, if for any reason you encounter difficulties, both our sales office and our technical assistance force is at your complete disposal; we can provide you with speedy repair services and we would like you to know that we are with you all the way. We would like to remind you also that all our machines are accompanied by an "CE" declaration of conformity which testifies that the machine conforms to required safety standards. Every machine must be accompanied by this declaration of conformity.

We would like to warn you that it is very important to keep this document in a safe place because the machine must always be accompanied by this document even if it is resold.

Thank you very much for taking the time to read this welcome message and we would like to remind you once again that we are at your complete disposal for any further information.



CONTENTS

Introduction.

Section 1: Safety

- 1.1. General information
- 1.2. Regular safety procedures
- 1.3. Use of protective devices
- 1.4. Manual movement of machine

Section 2: Description of machine

- 2.1. Detailed description
- 2.2. Electrical diagram
- 2.3a. Detailed diagram of machine - Water System Base Plate
- 2.3b. Detailed diagram of machine - Sliding Wheels Base Plate

Section 3: Instructions for setting up machine

- 3.1. Electrical supply
- 3.2. Water supply

Section 4: Use and maintenance

- 4.1. Use
- 4.2. Maintenance
- 4.3. Environmental protection warning

Section 5: Aerial noise and vibrations of the machine

- 5.1. Aerial noise
- 5.2. Vibrations

Section 6: Use of tools

- 6.1. Instructions for using tools on the **MASTER 3500** from grinding to polishing of toroidal profiles on granite
- 6.2. Instructions for using tools on the **MASTER 3500** from grinding to polishing of toroidal profiles on marble

Section 7: Safety



INTRODUCTION

The **MASTER 3500** is an electrical contouring machine used to work on marble and granite. The electrical supply is very low tension for safety reasons (SELV of 48V efficient value of alternate current) and is supplied via the use of a safety electrical conversion unit which complies with the norm CEI EN 60742.

Principal characteristics:

- Versatile when working with different kinds of profiles.
- Simple to operate and to use.
- Safe to use.
- Easy to transport.
- Robust.

The **MASTER 3500** has been designed and built in accordance with the machinery directive 89/392/EEC and the subsequent variations 91/368, 93/44 and 93/68.

DOCUMENTS

The instructions booklet, the electrical layout, the guarantee and the declaration of **CE** conformity must accompany the machinery at all times.

Compliance with the suggestions and warnings mentioned in this booklet is important in order to ensure that the machine works properly and in order to ensure that there is no need to request assistance under guarantee. Safety measures must be strictly observed in order to avoid any accidents.

MANUFACTURER'S DETAILS

MARMOELETTRROMECCANICA S.r.l.
Via Flaminia Km. 41,400
00068 Rignano Flaminio (Roma) - ITALY
Tel. +39 **0761 50.51**
Fax +39 **0761 50.83.88**
E-mail info@marmoelettro.it
[Http://www.marmoelettro.it](http://www.marmoelettro.it)

All rights are reserved to MARMOELETTRROMECCANICA S.r.l. even when protection is requested.



The information provided in this manual has been carefully compiled and checked in order to be as precise as possible, but MARMOELETTRROMECCANICA S.r.l. reserves the right to make changes or modifications as necessary when improvements have been made to the products themselves.

TECHNICAL DATA

Model:	MASTER 3500 CE
Electrical Tension:	48 V
Electrical supply:	3 ~
Nominal Power:	3000 W or 3 KW
Minimum number of nominal revs:	3000 min ⁻¹ /rpm
Maximum number of nominal revs:	6000 min ⁻¹ /rpm
Weight without tool:	39 kg
Maximum Diameter of tool:	140 mm

STANDARD ACCESSORIES SUPPLIED WITH MACHINE

- 50 MESH 1/2 MF Filter (Only for Master 3500 with Water System).
- Water Guard.
- Apron.
- T-handle for attachment of 5mm wheels.

TRANSPORT and STORAGE

In order to avoid any risk of deterioration, the machine must be transported and stored in its original box and stored in a dry place.

If stored as indicated, the machine will remain in perfect working order for a long time.

When storing the machine or when moving the machine in its original box (weight KG 44), all manual operations must be carried out in such a way as to avoid and reduce any risk of damage to the operator's back (see paragraph 1.4 – manual movement of machine).



SECTION 1: SAFETY

1.1. General Information

It is advisable that all users of the **MASTER 3500** read all of this booklet carefully before using the machine. This instruction manual provides advice regarding safety in the workplace which is very important in order to avoid any danger to the health of the operator.

There are several plates on the machine which indicate the tension, correct rotating direction of the parts and general warnings; the instructions on these plates must be carefully observed and respected.

Before using the machine you must check very carefully that the shaft has been placed in the correct direction of movement with respect to the cover of the machine. Otherwise the tool might become loose from the fitting while working and will consequently stick out.

If the machine should break down or if it does not work properly, turn it off and do not tamper with it. If it has to be repaired, please contact our assistance centre.

The **MASTER 3500** is a portable electrical contouring machine to be used exclusively when processing and grinding marble and granite.

MARMOELETTROMECCANICA S.r.l. will not be held responsible for damage caused by improper or unreasonable use.



WARNING!!! The **MASTER 3500** works on alternate threephase 48 volts electricity supply, therefore it must not, by any means, be connected directly to the mains electrical supply; it should only be connected to the central conversion unit **MEM 3000** which transforms the voltage at an entrance voltage of 48 volts.

Before turning the machine on, it is important to:

- Carefully check that the safety devices are in perfect running order. Never use the machine if the ON/OFF buttons or the speed button do not work perfectly.
- Check that the mobile parts work perfectly, that they are not blocked or that they are not damaged. **Check that the spindle lock pin is in the correct position of off.**
- Check and remove spanners and assembling tools from mobile parts.
- Check that all of the components have been mounted correctly and ensure that everything is in perfect working order for the machine.



Furthermore, during use of the **MASTER 3500**, you must:

- Avoid using the machine near flammable liquids or in dangerously explosive environments.
- Prevent other people from standing near the place of operation.
- Avoid wearing wide garments or jewellery which might be caught up in the parts in movement. If you have long hair, it is advisable to wear a suitable hairnet or to tie it up.
- Use suitable blockage devices in order to prevent the piece of material you are working on from moving; use for example the **H50 BI-SUCTION CUPS** which are produced by us. In this way you will be able to work more safely and you have both hands free to work with.
- Ensure that there is adequate light in the workplace.
- Stand in a safe and balanced position.
- Avoid moving or lifting the machine in such a way that you might damage your back; set up your workplace and organise it in such a way as to reduce the need to have to strain your back; use the **WORKING TABLE** equipment (see paragraph 1.4).
- Abide by and always follow the instructions for the changing of the tools which are subject to wear.
- Do not use utensils on the machine to do jobs which this machine is not designed to do.
- Avoid lifting the machine and holding it by the electricity cable which would cause the cable to be unplugged from the mains electricity supply.
- The electricity cable must not come into contact with surfaces which are extremely hot, with oil or sharp edges or corners.
- Use outside or outdoors by attaching the correct type of extension lead
- Turn the machine off before transporting it in order to avoid any accidents
- Take care and concentrate while working avoiding unreasonable behaviour or improper use of the machine.

Finally, it is important to:

- Keep the machine in a dry, safe environment where it must be kept out of the reach of children.
- Make sure you clean the tools very well after use in order to guarantee efficient, safe work and ensure that the tools are cleaned following the specific guidelines for their maintenance.
- Check the electricity cable and the plug periodically and if there should be any damage, contact qualified technicians only for their replacement.
- Check the electricity extension lead of the central conversion unit and change it when it is damaged.



1.2. Regular safety check-up

This machine has been designed and built in accordance with the principle of integration of safety measures with that of technical requirements. This machine can be dangerous if used by incompetent workers or if it is used for jobs that it was not designed for.

Therefore it may:

- be dangerous for the operator;
- cause damage to the machine or any other inconvenience;
- cause the machine to break down.

In order to ensure perfect functioning and safety of the machine, always make sure that the machine is repaired exclusively by qualified personnel and that original spare parts or tools are used to replace old ones. Any spare parts, accessories or tools that are not supplied by the producer of the machine have not been tested or approved by the same. The attachment or use of such products may create technical difficulties to the machine and therefore make it less safe.

1.3. Use of personal protection measures

Even though the **MASTER 3500** has been designed and built very carefully and special attention has been given to ensuring that there is no danger, it is advisable for the operator to wear (DPI) individual protective devices such as : goggles, gloves, protective shoes and earphones if there is any danger of damage to your hearing. These measures are necessary so that the health and safety regulations prescribed by the specific law are observed.



1.4. Manual movement of the machine

By manual load movement, we mean the operations of transport and lifting of a load by one or more operators, including the picking up, setting down, pulling, pushing and moving of one load that might cause back problems.

The use of the **MASTER 3500** entails moving loads especially when putting the machine on the slab at the beginning or when the tool has to be changed.

Under these circumstances, it is important to carry out these operations by taking the necessary precautions while moving the machine thus avoiding:

- lifting from the ground or placing above the shoulders (do not put the machine on the ground or on shelves that are too high or too low). In fact it is preferable to move the machine within the area of the shoulder and the knuckles (hand in fist position held along the sides),
- lifting and moving the machine by rotating the bust just once,
- keeping the machine too far from the body while carrying it or moving it,
- placing it on worktops which are too high causing you to arch your back too much,
- lifting it from the ground with a bent back,
- moving the machine by hand for long trips or up stairs,
- moving the machine with only one hand,
- picking the machine up too quickly.

SECTION 2: DESCRIPTION OF THE MACHINE

Water System Base Plate

Your MASTER 3500 is equipped with the **WATER SYSTEM** which is a new gliding base plate. This revolutionary gliding system is patented by MARMOELET-TROMECCANICA S.r.l. and it allows the machine to glide with a rather clever film of water flowing between the slab and the machine. The **WATER SYSTEM PLATE** permits you to work on narrow strips of up to 10 cm. too and at practically no maintenance costs and very quickly too.

! WARNING!!! Make sure that there is water before starting to work with the MASTER 3500 on the marble or granite slab - this avoids causing any damage to the WATER SYSTEM plate and scratching of the surface of the slab.

2.1. Detailed description

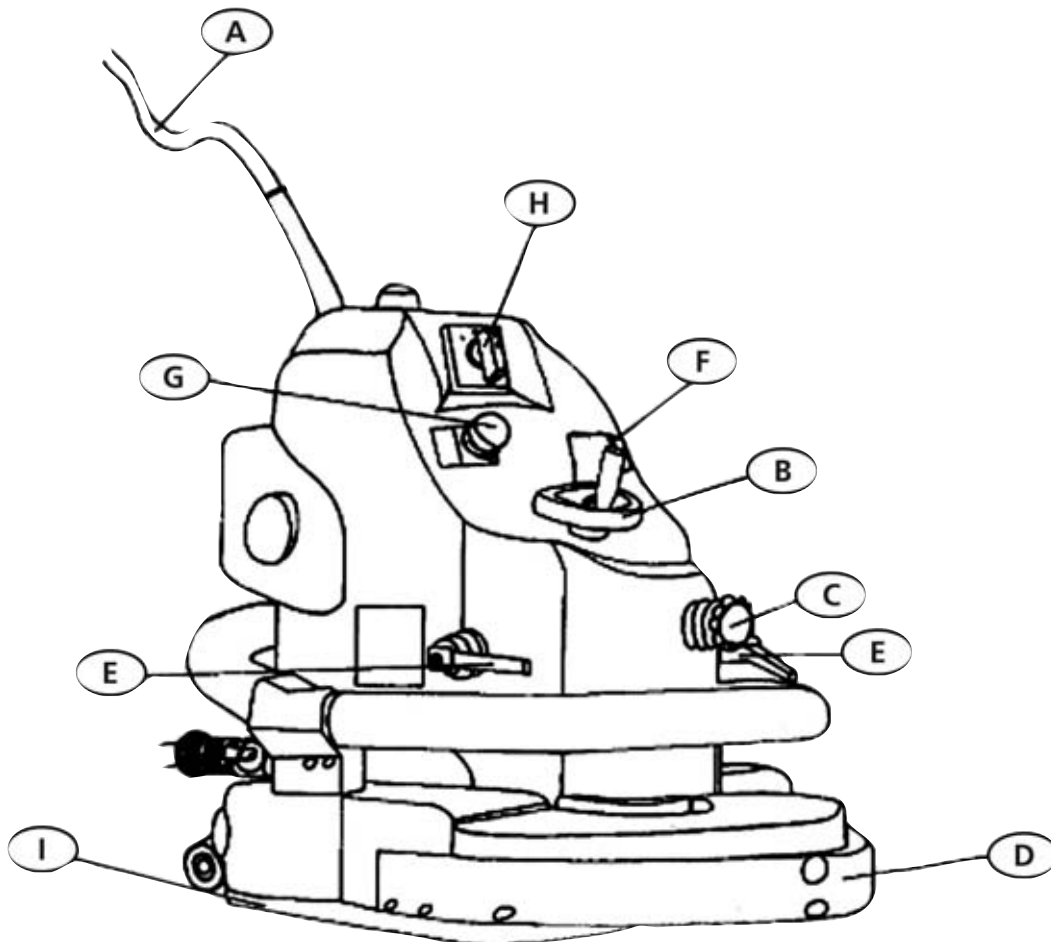

- A. Electrical cable:** the 48 volt current has to travel 6 metres long; the cable must always be connected to the central conversion unit by a special plug.
- B. Adjustment handle for positioning the tool correctly:** release the spring handles so that you can regulate the position of the tool to the slab in function of its thickness
- C. Spindle lock pin:** by a clockwise movement, turn the pin in order to block the spindle and change the wheel. Then, make sure that said pin is released before switching the machine on again.
- D. Water spray system:** the machine is equipped with 4 adjustable water jets and a system for washing the surface which ensures that the bits cool down and that dust does not build up.
- E. Spring handles:** the spring handles, when turned clockwise, block the position of the tool with respect to the slab during operation.
- F. ON button:** this is a special black switch which ensures that the machine cannot be accidentally turned on. This switch is marked with "**ON**".
- G. Stop button:** red stop switch is marked with "**OFF**" gives you the possibility to quickly turn off the machine even in an emergency.
- H. Variable speed switch:** this switch allows you to vary the spindle speed (3000-6000 rpm) depending on which wheel/tool is being used (see instructions for use of tools).
- I. WATER SYSTEM:** this gliding base plate, thanks to a rather clever film of water flowing between the slab and the machine, allows the machine to glide on the surface of a slab.



2.2. ELECTRICAL DIAGRAM

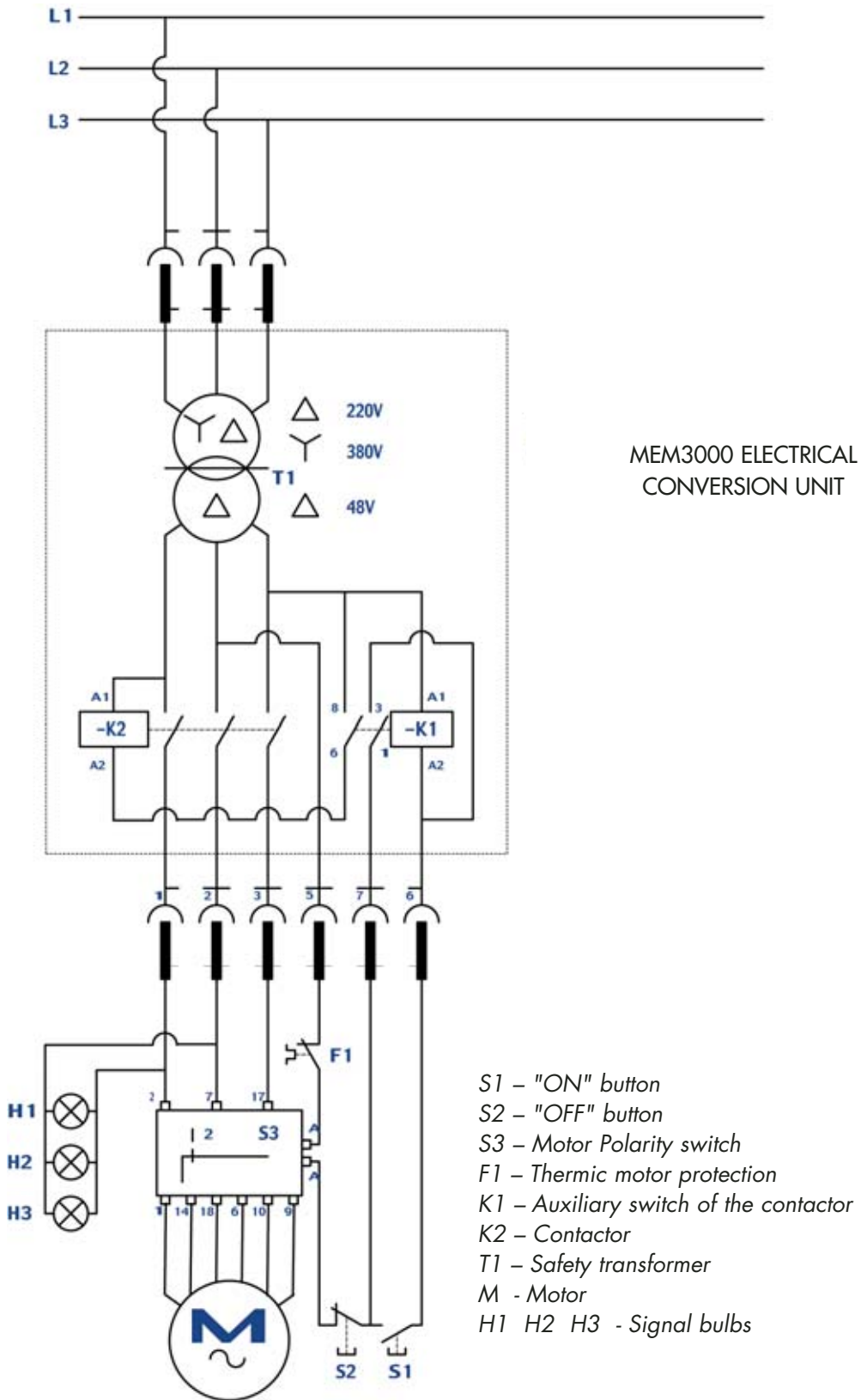

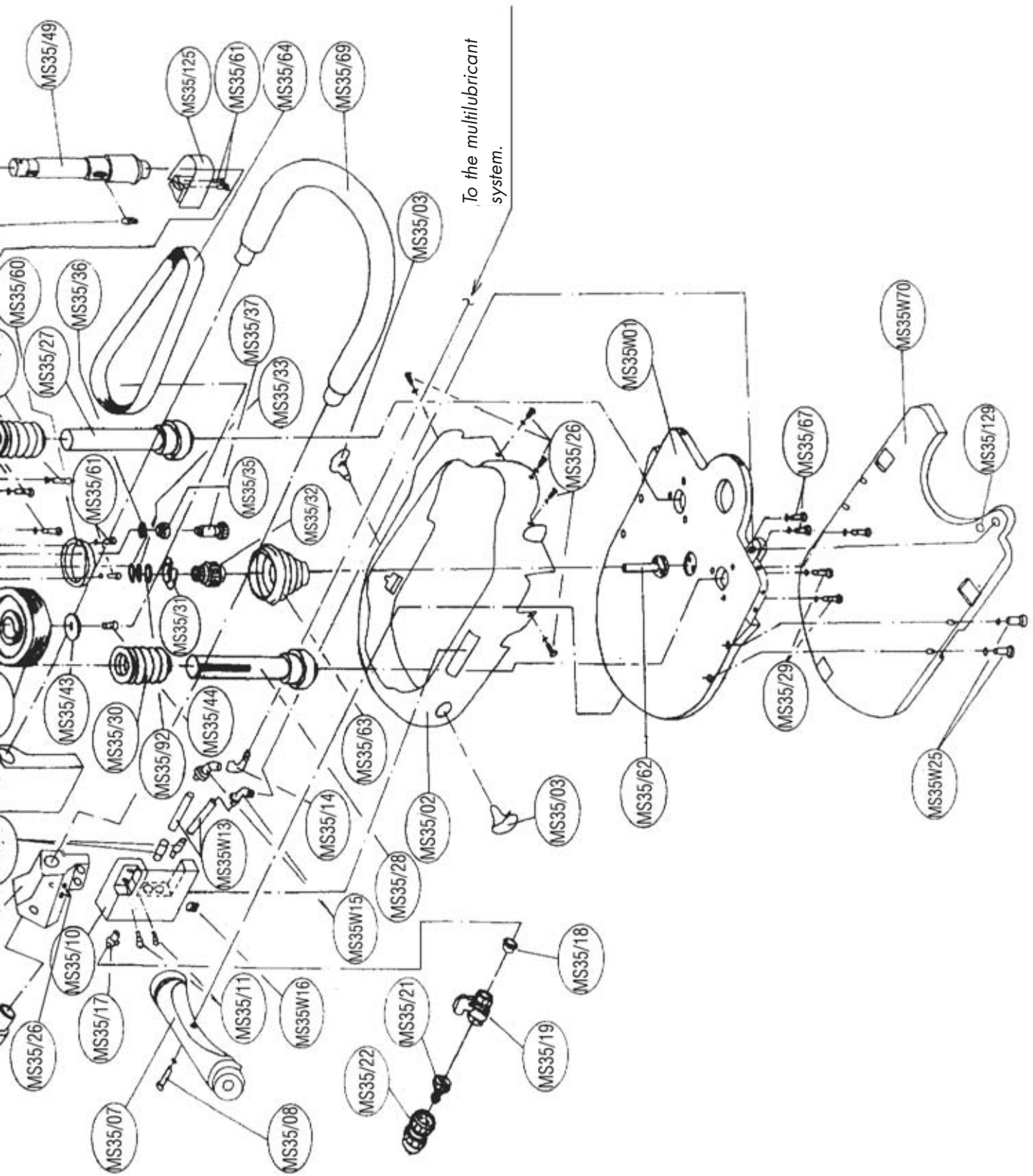

2.3b. DETAILED DIAGRAM OF THE MASTER 3500

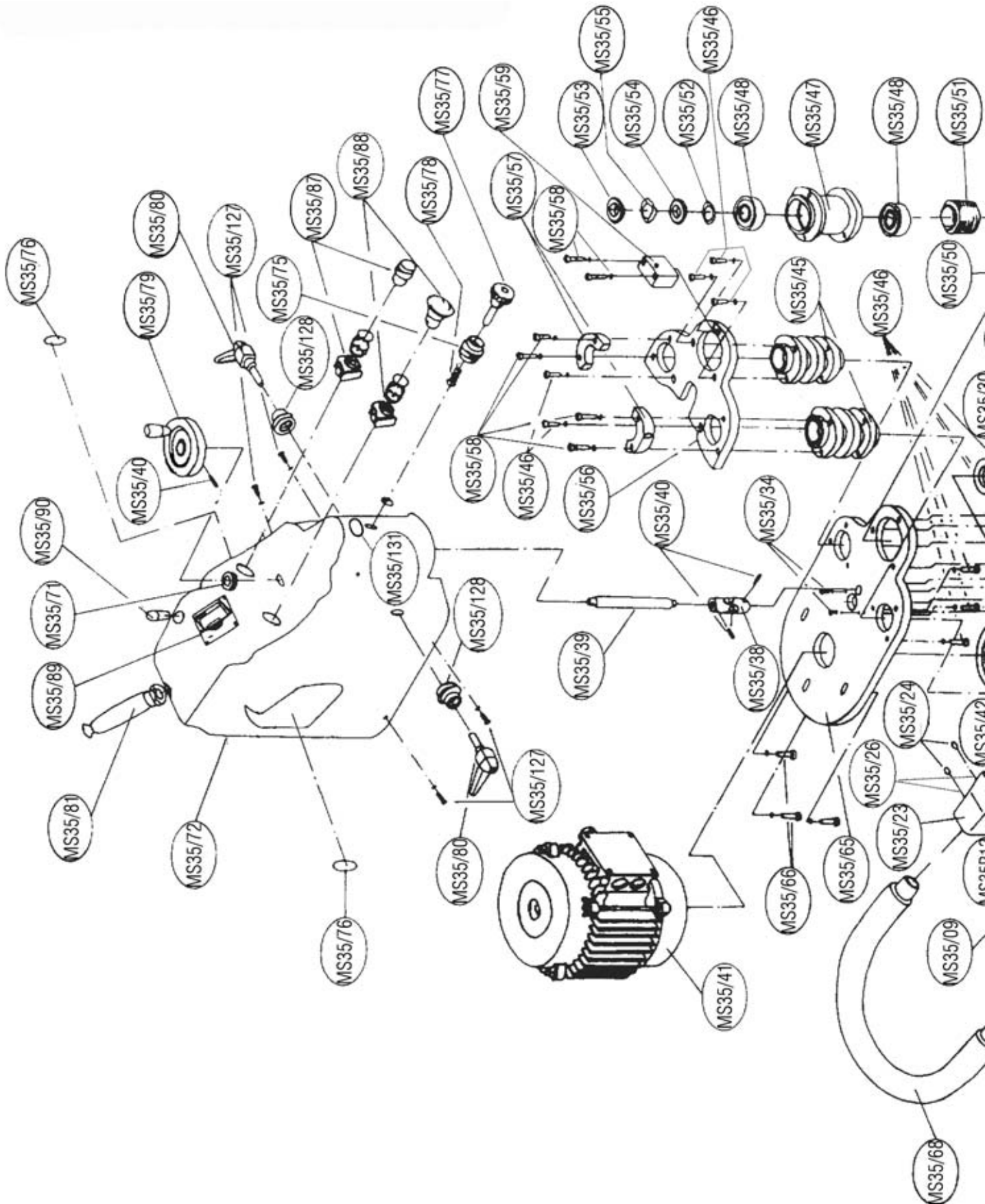

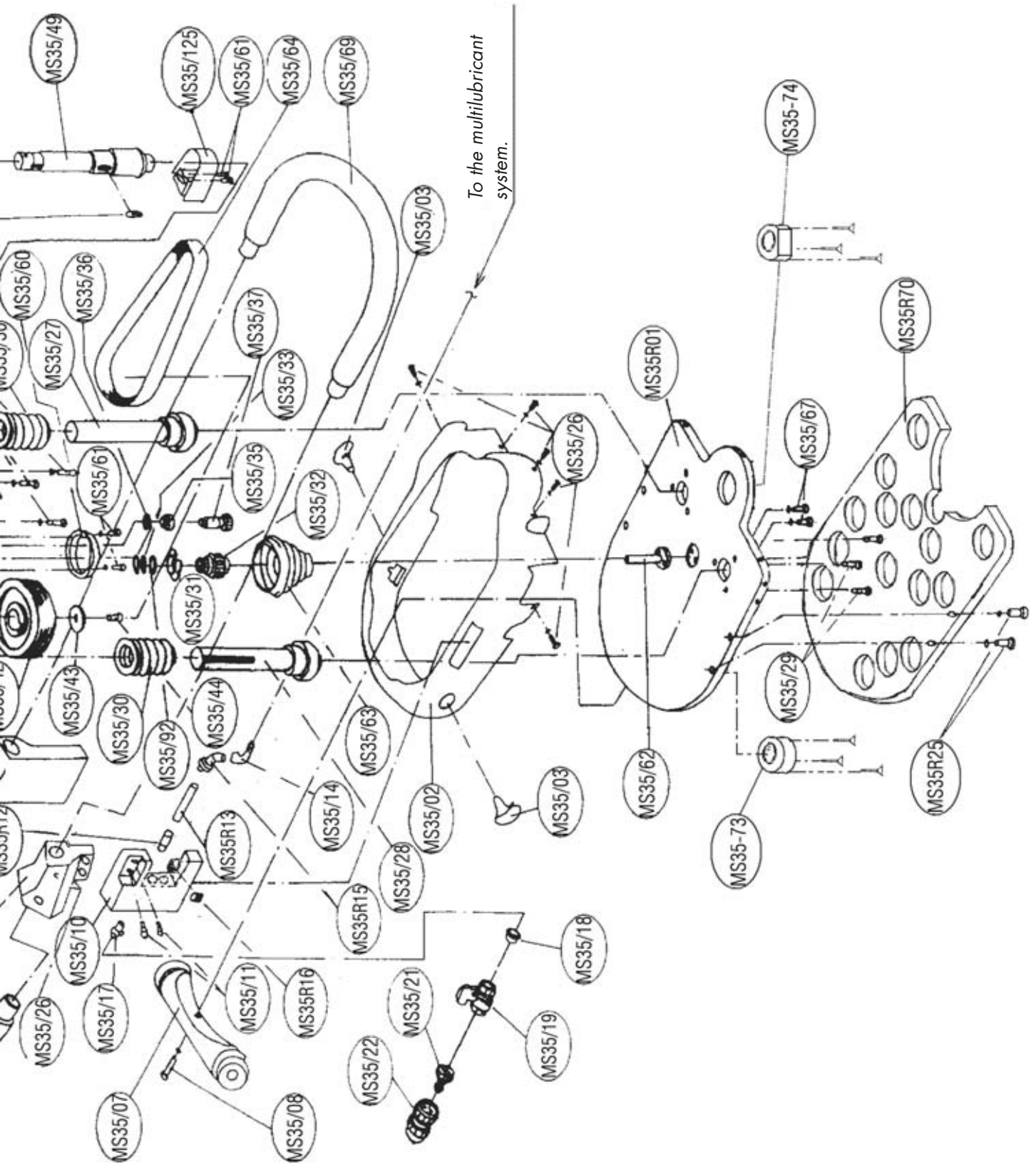

Detailed diagram of multilubricant system

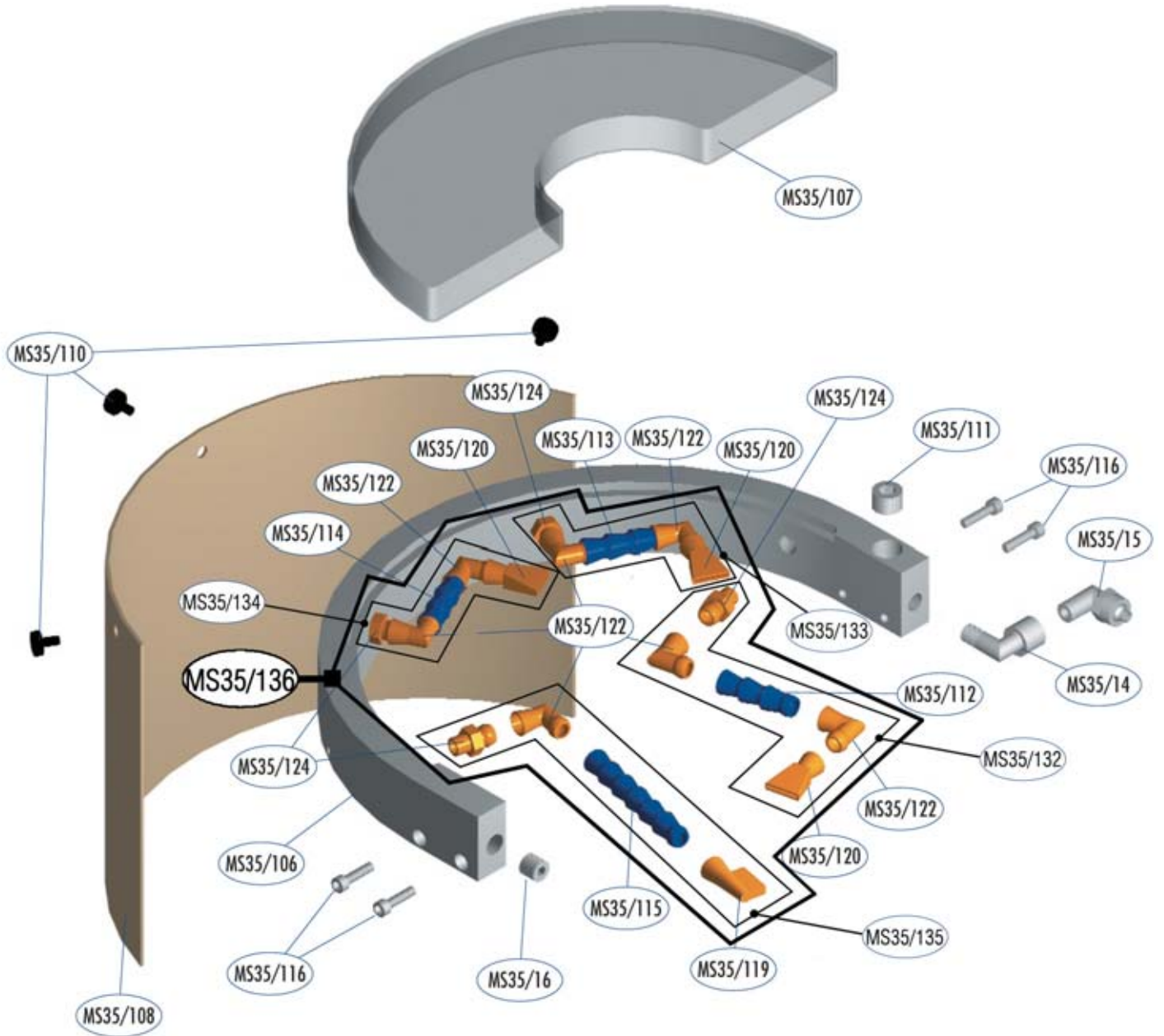

Detailed diagram of top cover

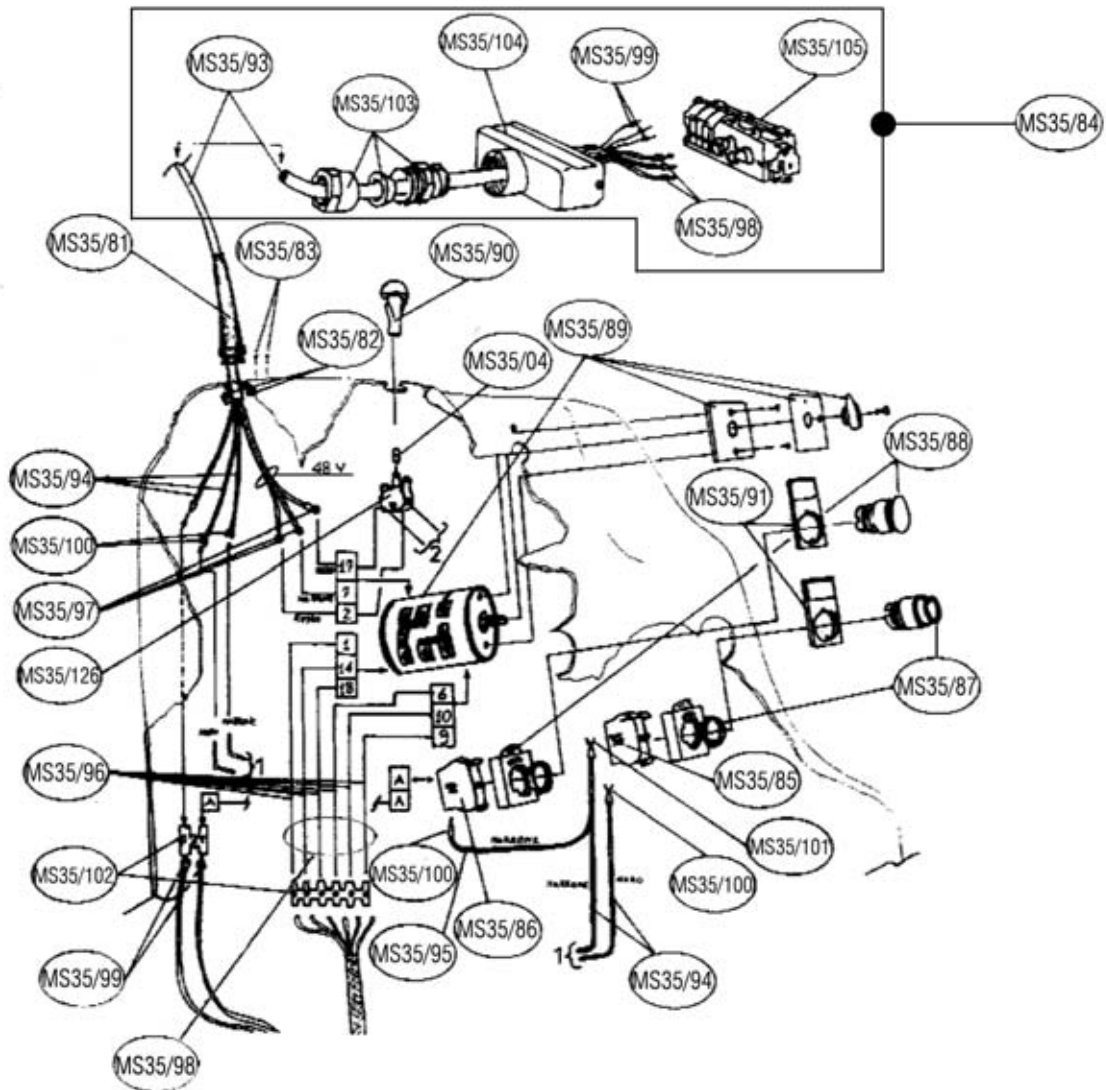

Detailed diagram of side taillights

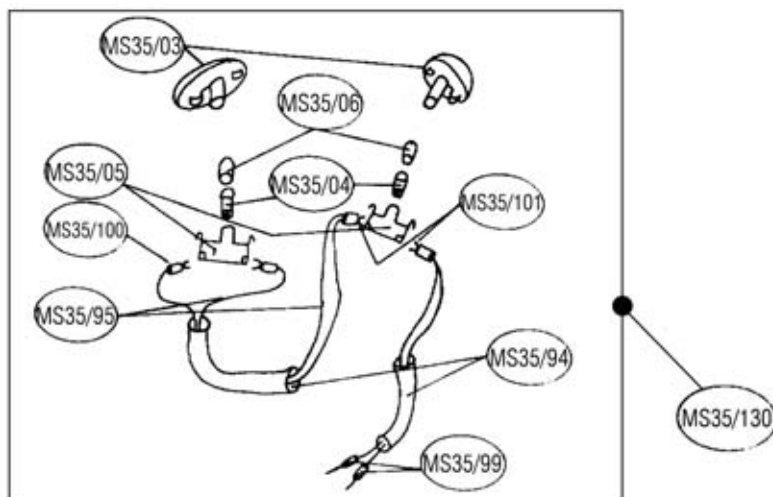

Detailed Diagram of Upsetting Support



Stickers



MASTER 3500 - List of codes on detailed diagrams

PROG.VE	Qty.	DESCRIPTION	CODE
MS35R01	1	BASE PLATE	PIASTRABASEMS
MS35W01	1	ALLUMINIUM BASE PLATE FOR MASTER 3500	MS35PIASTRABA
MS3502	1	GREY PLASTIC COVER	MS35CARENINF
MS3503	2	SLIPPAGE FERRULES	MS35FANAELAT
MS3504	3	LIGHT BULBS (TOP OF MACHINE)	MS35LAMPADA48
MS3505	2	MASTER 3500 LAMP SOCKETS	MS35PORTALAMP
MS3506	2	THREADED HOLDERS	MS35BOCCARIDU
MS3507	1	UPSETTING SUPPORT WITH ROULERS	SUPPORTORIBCR
MS3508	1	TCCEI M 6x30 SCREW WITH WASHER Ø6mm	VITETCCE630
MS3509	1	LEFT HANDLE SUPPORT - UPPER PART	MS35SUPPMASUP
MS3510	1	LEFT HANDLE SUPPORT - LOWER PART	MS35SUPPMAINF
MS3511	2	6x10 TCCE A2 INOX SCREWS	VITETCCE610
MS35W12	2	1/4 FAST PIPE ATTACHMENTS FOR 10x8 TUBE	MS35RACCORDRA
MS35R12	1	1/4 FAST PIPE ATTACHMENTS FOR 10x8 TUBE	MS35RACCORDRA
MS35W13	cm 21	RILSAN DIAM. 10x8 TUBE	TUBORILSA10
MS35R13	cm 6	RILSAN DIAM. 10x8 TUBE	TUBORILSA10
MS3514	1	MF 1/4 ELBOW	GOMITO1/4MF
MS35W15	2	1/4" "ELBOWS FOR DIAM. 10 TUBE"	MS35GOMITO1/4
MS35R15	1	1/4" "ELBOWS FOR DIAM. 10 TUBE"	MS35GOMITO1/4
MS35W16	2	1/4 SCREW CAPS	MS35TAPPOSC14
MS35R16	3	1/4 SCREW CAPS	MS35TAPPOSC14
MS3517	1	3/8 CILYNDRICAL NIPPLE	NIPPLO3/8
MS3518	1	THREADED ADAPTOR	RIDUZFILETTA
MS3519	1	BALL VALVE	GTRUBMIGN108
MS3520	1	CYLINDRICAL NIPPLE	NIPPLOCIL
MS3521	1	1/2 THREADED TAP CONNECTOR	ADATTATO6683
MS3522	1	THREADED TAP CONNECTOR	RACCORDTUB215
MS3523	1	RIGHT HANDLE SUPPORT	SUPPMANIDX
MS3524	4	C E P FLAT 8x8 STEEL SCREWS	GRANOPPIAT88
MS35W25	4	TCCEI M 8x30 A2 INOX CYLINDRICAL BOLTS	VITETCCE830
MS35R25	4	TCCEI M 8x20 SCREWS	VITETCCE820
MS3526	9	M 4x8 BUTTON SCREW	VITEBUTTON48
MS3527	1	RIGHT SLIPPAGE GUIDING BARS+RIGHT SLIPPAGE GUIDING SUPPORT	BASECOLONDX
MS3528	1	LEFT SLIPPAGE GUIDING BARS+LEFT SLIPPAGE GUIDING SUPPORT	BASECOLONSX
MS3529	6	TCCEI M 5x25 SCREWS	VITETCCE525
MS3530	2	BELLOWS FOR GUIDING SUPPORT	GUARNIZIONE01
MS3531	1	STEEL NUT	GHIERAACC

PROG.VE	Qty.	DESCRIPTION	CODE
MS3532	1	M1 Z31 ADJUSTING PINION	MS35PIGNONERE
MS3533	2	Z31 BRASS NUT	GHIERAOTTZ31
MS3534	2	M 3x10 RECTIFIED SCREWS	VITETCCE310
MS3535	1	PINION HOLDER FERRULE	BOCLAPRPIGNO
MS3536	1	BRASS NUT	GHIERAOTT
MS3537	1	M1 Z15 ADJUSTING PINION	PIGNONEZ15
MS3538	1	HINGED JOINT	GIUNTOSNODO
MS3539	1	ADJUSTING PIN	MS35PERNOREGI
MS3540	3	3x20 ELASTIC PLUGS	SPINAELA320
MS3541	1	ELECTRIC MOTOR 100 R2 B14 2/4P	MOTOREB142/4P
MS3542	1	DRIVE SHAFT FOR MASTER 3500	MS35PULEGMOTO
MS3543	1	WASHER	RONDELLAMS
MS3544	1	TPSIC M 6x16 SCREW	VITETPSE616
MS3545	2	SLIPPAGE FERRULES	MS35DISTSCORR
MS3546	14	5x16 INOX RECTIFIED SCREWS	VITETCCE516
MS3547	1	SPINDLE FERRULE	BOCLAPRMANMS
MS3548	2	6205 2RS BALL BEARINGS	CUSCINETTO03
MS3549	1	SPINDLE	MANDRINOMS
MS3550	1	6x6x25 FEATHER KEY	LINGUETTA
MS3551	1	DRIVEN SHEAVE	MS35PULEGCOND
MS3552	1	BAUER DISK SPRING	MOLLATAZZA
MS3553	1	KMA 5 BLOCK NUT	GHIERABLOC1
MS3554	1	KMA 5 NUT	GHIERABLOC
MS3555	1	MB 5 SLOT WASHER	RONDELLAMB5
MS3556	1	UPPER PLATE	MS35PIASTRASU
MS3557	2	SLIPPAGE LOCK SUPPORTS	LUNETTABLOC
MS3558	6	TCCEI M 5x35 SCREWS	VITETCCE535
MS3559	1	BLOCK SPINDLE SUPPORT	MS28SUPPBLOCC
MS3560	1	BELLOW RING	ANELLOPORTA
MS3561	4	TCCEI M 4x20 SCREWS	VITETCCE420
MS3562	1	ADJUSTING THREAD DOWEL	MS35VITEBATT
MS3563	1	BELLOW	SOFFIETTO50
MS3564	1	BELT FOR MASTER 3000/3500	CINGHIAPOL02
MS3565	1	MOTOR SUPPORT BASE	MS35PIASTRAMO
MS3566	3	TCCEI M 8x20 SCREWS	VITETCCE820
MS3567	2	5x16 INOX RECTIFIED SCREWS	VITETCCE516
MS3568	1	BACK HANDLE	MANICOPOST
MS3569	1	FRONT HANDLE	MANICOANTE

PROG.VE	Qty.	DESCRIPTION	CODE
MS35W70	1	WATER SYSTEM PLATE	MS35PIASTRAWS
MS35R70	1	LOWER PROTECTION PLATE FOR MASTER 3000	AERSTOPA10
MS3571	1	DUST SEAL	GOMMINO122024
MS3572	1	FIBREGLASS UPPER COVER	MS35CARENSUPE
MS3573	15	COMPLETE ROLLERS MEM 22	RUOTAPORTA
MS3574	1	CUTTED ROLLER MEM 22*	RUOTAMEM22FRE
MS3575	1	BELLOW	SOFFIETTO12
MS3576	2	ORANGE REFLECTOR	MS35CATADIOTT
MS3577	1	LOCK SPINDLE PIN	PERNOBLOCMAND
MS3578	1	INOX SPRING	MOLLAINOXLS
MS3579	1	MASTER 3000 WHEEL ADJUSTMENT HANDLE	GAMMVPRA80
MS3580	2	WHEEL LOCKING SPRING HANDLE	MANIGLIASCM10
MS3581	1	WHEEL LOCKING SPRING HANDLE	PASSACAVO
MS3582	1	PLASTIC BLOCK CABLEPIN	MORSETTCAVOMS
MS3583	2	M 4x20 BUTTON SCREWS	VITEBUTTON420
MS3584	1	CABLE WITH NEW PLUG CE FOR LS/MS 3500	CAVOALIMLSCE
MS3585	1	CONTACTOR BLOCK - SWITCH ON	CONTATTO1NA
MS3586	1	CONTACTOR BLOCK - SWITCH OFF	CONTATTO1NC
MS3587	1	BLACK START BUTTON	PULSANTE73
MS3588	1	RED STOP BUTTON	PULSANTE74
MS3589	1	32 A COMMUTATOR	COMMUTAT32A
MS3590	1	ORANGE LIGHT COVER	LMPD0008
MS3591	2	ON/OFF PLATE	TARGHETTANEU
MS3592	1	Z31 BRASS WASHER	RONDOTTZ31
MS3593	6 mt	BLUE CABLE (6meters)	CAVOFLES155AR
MS3594	cm500	GLASS SILICONE TUBE Ø6	TUBSILICON6
MS3595	cm400	1,5mm SINGLE CABLE	MS35CAVOFLES1
MS3596	cm240	6mm SINGLE CABLE	MS35CAVOFLES6
MS3597	9	YELLOW EYELET THIMBLES	CAPICOCCH6GI
MS3598	17	YELLOW POINT THIMBLES	CAPICPUNT60GL
MS3599	9	RED POINT THIMBLES	CAPICPUNT15RO
MS35100	9	RED FORK THIMBLES	CAPICFORCM4RO
MS35101	3	BLUE FORK THIMBLES	CAPICFORCM4BL
MS35102	10	SCREW TERMINALS	MORSETTIEP6
MS35103	1	CABLE GLAND	PRESSACAVO
MS35104	1	HOUSING FOR INSERT	CUSTODIAMOB
MS35105	1	MALE INSERT	FRUTTOSPINA
MS35106	1	WATER CURVED SUPPORT	SUPPIDRIIP691
MS35107	1	MASK	PROTRASIP69/2

PROG.VE	Qty.	DESCRIPTION	CODE
MS35108	1	PROTECTIVE ANTISPLASH GUARD	MASCHERAIP693
MS35110	3	BLACK PLASTIC SCREWS	POMELNEIP69/5
MS35111	1	3/8 SCREW CAP	MS35TAPPOSC38
MS35112	1	1/4 LUBRICATION LOC-LINE TUBE	MS35TUBOLUBRIP
MS35113	1	1/4 LUBRICATION LOC-LINE TUBE	MS35TUBOLUBRIP
MS35114	1	1/4 LUBRICATION LOC-LINE TUBE	MS35TUBOLUBRIP
MS35115	1	No. 6 PCS OF 1/4 WATER PIPE	TUBOLUBRIP6910
MS35116	4	TCCEI M 5x25 SCREWS	VITETCCE525
MS35119	1	1/4" "SAY BAR NOZZLE CODE 69/16"	CURVPETIP6916
MS35120	3	1/4" "FLARE NOZZLES"	UGELLOIP6920
MS35122	7	1/4 MF LOCLINE CURVE	CURVETTIP6919
MS35124	4	1/4" "CONNECTOR CODE IP 69/22"	ATTACFIP69/22
MS35125	1	COVER BELT	MS28MS35PROT
MS35126	1	LAMP SOCKET FOR ORANGE LIGHT	PRTL0002
MS35127	4	M 4x16 A2 INOX SCREWS	VITEBUTTON416
MS35128	2	LOCKING ARM BELLOWS FOR MASTER 3000/3500	SOFFIETTOMANSCA
MS35129	1	OR3056 FOR WATER SYSTEM PLATE	PWSOR3056
MS35130	1	LATERAL INFERIOR LIGHTING SET	KITILLUMILAT
MS35131	1	ROTATION SENSE INDICATOR	TALLSROT
MS35132	1	LOC LINE WATER PIPE	MS35USCITA1
MS35133	1	LOC LINE WATER PIPE	MS35USCITA2
MS35134	1	LOC LINE WATER PIPE	MS35USCITA3
MS35135	1	LOC LINE WATER PIPE	MS35USCITA4
MS35136	1	MASTER 3500 PART LUBRICATION OUTPUT FOR MULTILUBRICANT SYSTEM	MS35USCITE1234
MS35137	2	RUBBER RINGS FOR UPSETTING SUPPORT WHEELS	MS35ORRUTESUP
MS35138	2	ROULERS FOR UPSETTING SUPPORT	RUOTESUPPRIBA
MS35139	2	SEEGER RINGS D10 FOR EXTERNAL PART IN ACC.	ANELSEEG47110
MS35140	1	"ALTO-UP" STICKER CM 3x4,5	ADESIVOALTO
MS35141	1	"BASSO-DOWN" STICKER CM 3x4,5	ADESIVOBASSO
MS35142	1	TRANSPARENT STICKER WITH SILVER WRITING	MS35ADESIVOTR
MS35143	1	TRANSPARENT STICKER WITH SILVER WRITING	MS35ADESIVO
MS35144	1	UPSETTING SUPPORT WITH PINS	SUPPRIBAL

SECTION 3: ISTRUCTIONS FOR SETTING UP MACHINE

3.1. Electricity supply

Under no circumstances should the **MASTER 3500** be connected directly to the electricity supply. You must connect it to the very low tension electrical conversion unit **MEM 3000** (SELV - Safety extra low voltage) manufactured by us.

Before connecting the unit to the electricity supply, please ensure that the rating on the plate affixed to the machine corresponds to the rating of the mains power supply and that the electrical charge of the socket, which should be the interlock type, (CEI 23-12), is suitable for the power of the machine.

ANY PROBLEMS ARISING FROM AN INCORRECT VOLTAGE IS NOT COVERED BY OUR GUARANTEE.

The electrical connection should be made exclusively with cables, plugs and sockets that comply with the EC Norms and in accordance with the EC directives of low tension 73/23 and subsequent modifications; in particular it is necessary to use cables with no interruptions and the cable section of the plug should be adaptable to the absorption power of the machine.

It is forbidden to use multiple adaptors and plugs; **MARMOELETTROMECCANICA S.r.l. CAN NOT BE CONSIDERED RESPONSIBLE** for incorrect installation that might cause damage to people and things.

Our clients are reminded also of the necessity to verify, before using the machine, the rotating direction of the spindle of the **MASTER 3500**; the rotating direction should correspond to the indicator marked on the cover of the machine. Otherwise it is necessary to exchange two of the three wires in the power supply plug.

3.2. Water supply (Only for Master 3500 with Water System Base Plate)

In order to avoid that the holes of the WATER SYSTEM plate get clogged up with foreign bodies present in the water supply of the **MASTER 3500**, we advise you to use the 50 MESH _ MF. filter. The filter should be placed between the water supply and the water tap of the **MASTER 3500**.

Mesh 1/2 MF Filter 50

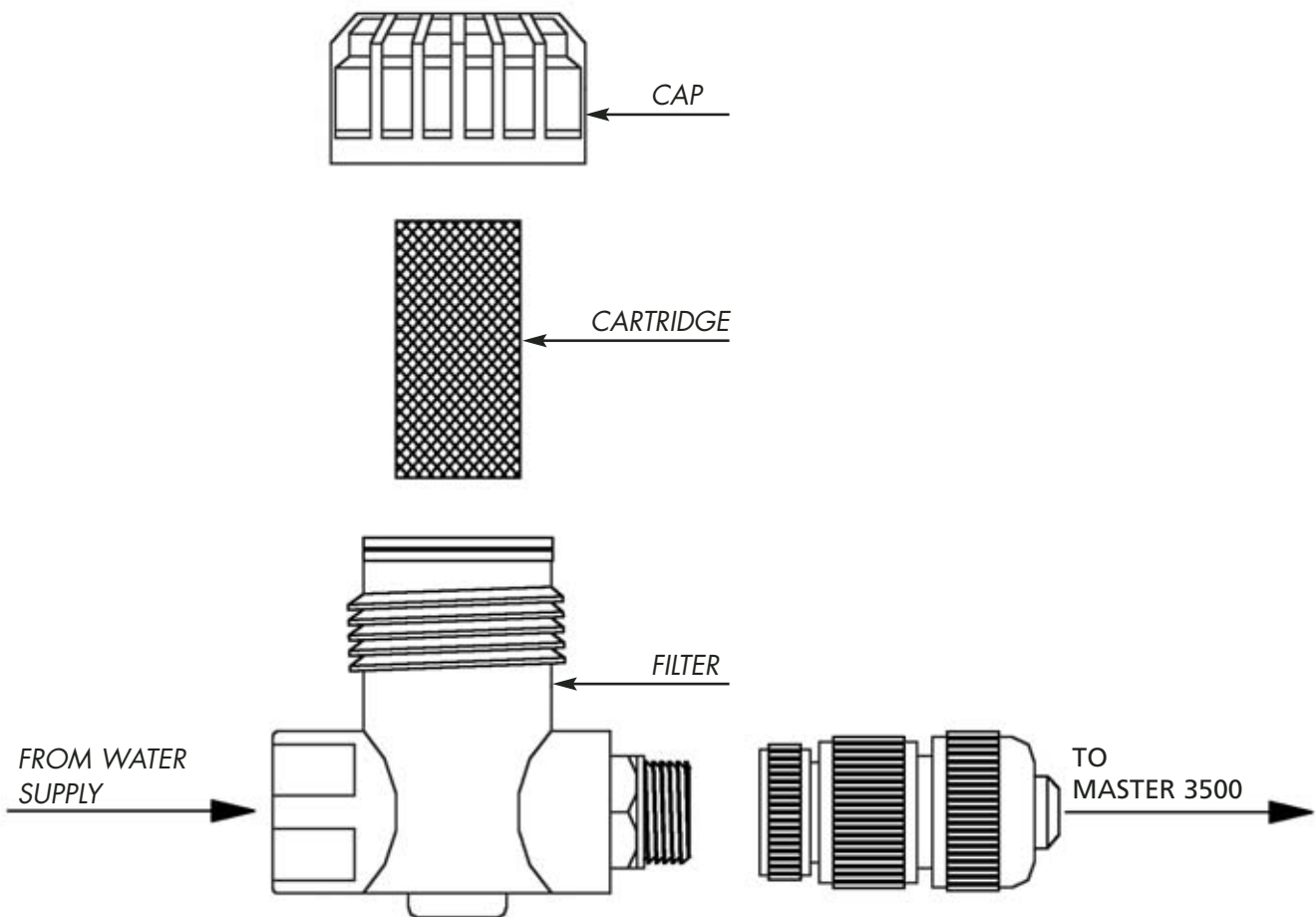

SECTION 4: USE AND MAINTENANCE

4.1. Use

Before starting to work with your machine, observe the following instructions carefully:

- connect cable (A) to electrical conversion unit, after making sure that the data on the plate correspond to that of your electrical supply;
- check position of multi-lubrication system nozzles (D) making sure that water pressure is at least 3 ATM.
- Carefully clean the marble slab surface and the gliding plate of the **MASTER 3500** in order to avoid any damage caused by foreign bodies;
- position the wheel correctly according to the thickness of the slab using the adjustment handle (B); to do so make sure that the spring-handles (E) are unscrewed;
- in order to change the wheels, screw lock spindle pin (C), turning clockwise; before starting to work make sure it is off;
- to avoid dangerous overheating we recommend that you unwind the cable from end to end;
- do not leave the machine plugged in while not in operation, switch it off at the mains;
- ensure that the suction grates used for cooling do not get clogged up.

4.2. Maintenance

- Before cleaning or carrying out maintenance, disconnect the machine from the electricity mains.
- It is advisable to grease the spring handles periodically; make sure they are blocked during operation.
- To ensure the correct functioning of **MESH 1/2 MF FILTER 50**, it is advisable to clean the filter cartridge periodically. To do this, unscrew the cap to remove the cartridge; clean it with water under pressure or compressed air.
- In order to avoid that the small holes of the **WATER SYSTEM** get clogged up, use an air pistol periodically to blow air on them.

4.3. Environmental protection warnings

When using your machine, It is important to follow current legislation when disposing of waste by products in order to respect and protect the environment.

Make sure you send any waste packaging, the machine itself at the end of its life cycle (scrap) and the worn out tools to an ecological recycling centre, via a waste disposal group which is as homogenous as possible to the original type of material.

Furthermore, we would advise you to recycle or treat the used water before disposing of it in waterways or in sewage disposal units.

SECTION 5: AERIAL NOISE AND VIBRATIONS OF THE MACHINE

5.1 Aerial noise

The Master 3500 machine, made to rectify, shaping and polishing stone materials, has made fonometric measurements by the production premises, in order to ascertain noise values. Measurements were made with a fonometer of claim 1 (norm IEC 651 group 1) put at 1,5 m.

The pondered level of acoustic pressure A made by the machine motor is $Leq=70,4$ dB (A).

5.2 Vibrations

The Master 3500 machine, after the valuation tests for the HAV vibrations according to D. Law. 187/05, showed not to exceed the following limits established by the norms:

Daily levels and limit exposure to vibration transmitted to the hand-arm system and to all body.

Vibrations transmitted to the hand-arm system

Daily exposure level
 $A(8)= 2,5 \text{ m/s}^2$

Daily exposure limit value
 $A(8)= 5 \text{ m/s}^2$

Vibrations trasmitted to all body

Daily exposure level
 $A(8)= 0,5 \text{ m/s}^2$

Daily exposure limit value
 $A(8)= 1,15 \text{ m/s}^2$



SECTION 6: USE OF TOOLS

6.1. INSTRUCTION FOR USE OF TOOLS ON THE MASTER 3500 – FROM GRINDING TOOLS TO POLISHING TOOLS ON TOROIDAL PROFILES OF GRANITE



WARNING!!! Before starting to work with your **MASTER 3500** please check that the rotating direction of the spindle corresponds to the indications on the machine; if otherwise, please invert two of the three wires in the plug.

Furthermore, the operator must not change the position of the spindle between one sequence and the next once the spindle has been positioned correctly for the POS. 1 tool; this would deform the **LONGLIFE** wheels (polishing wheels).

If this is done, **MARMOELETTRROMECCANICA**, will not cover any damages. Finally, we would like to remind you that the **LONGLIFE** polishing wheels need to be run in for a short period; for this it is advisable to use a metre of discarde material before starting.



WARNING!!! IT IS FORBIDDEN to use dirty water with the **LONGLIFE** tools. Before starting work, check that the water supply has a filter which will keep the water clean.

POSITION 1 - ZENITH/CROMOLINE/SALDOBRASA

BLUE Diamond grinding wheel with **ROTATING TOUCHER**:

Set the RPM switch at 6000. Move the machine towards the slab and press against it slightly. Move the machine a few centimetres both to the left and then to the right until the wheel itself idles: this means that the rotating toucher has touched the slab and at that stage, the first phase has been completed.

POSITION 2 - ZENITH/CROMOLINE

GOLD Diamond grinding wheel with **ROTATING TOUCHER**:

Continue by using the same care as for the Position number 1; this phase of operation is terminated when the rotating toucher touches the slab and the wheel is idle; after using Position 2 you will be able to see that the waves or irregularities left over from the Position 1 have disappeared and that the profile is homogenous.

POSITION 3 - BIPOWER

The Pos. 3 **BIPOWER** wheel will both rectify the profile and prepare it for the polishing phase. It is used by moving it from left to right and viceversa a minimum of 2/6 times at 6000 rpm, depending on the thickness of the slab and on how detailed

the profile shape is. We recommend that you make quick, constant passes giving a little push but avoiding any breaks in the operation so that there are no undulations.

N.B.: When Pos. 3 Bipower has already been used to complete quite a number of metres, it will be necessary to do a few extra passes in order to obtain a perfect profile.

POSITION 4 (4 extra) - **LONGLIFE**

Pass this wheel at 3000 rpm – make from minimum 4 passes to a maximum of 6 passes from left to right and viceversa pushing a little. Avoid any breaks during the operation in order to avoid any undulations.

POSITION 5 (5 extra) - **LONGLIFE**

Pass this wheel at 3000 rpm – make from a minimum of 6 passes to a maximum of 8 passes from left to right and viceversa pushing a little.

POSITION 6 (6 extra) - **LONGLIFE**

Pass this wheel at 3000 rpm – make from a minimum of 8 passes to a maximum of 12 passes from left to right and viceversa pushing a little.

NB: THE NUMBER OF PASSES THAT ARE REQUIRED MAY DEPEND ON THE MATERIAL, THE CLIENT'S REQUIREMENTS AND THE STATE OF WEAR OF THE WHEEL ITSELF.

POLYPASTE BOTTLE

POLYPASTE is a highly-concentrated solution (type of wax) of chemical polishing components, which easily remove the opaque layer left by atmospheric agents. It is particularly indicated to be used after the traditional polishing systems. Put **POLYPASTE** on a wool cloth, polish the slab till complete drying of the paste.



The **ZENITH/CROMOLINE POS.1 BLUE** wheels with **ROTATING TOUCHER** can be transformed into the following different profiles by simply changing the **ROTATING TOUCHER** (*n.b.: pos. 2 cannot be transformed*):



! WARNING!!! Such transformations can be made only on the **POSITION 1** grinding wheels, by simply ordering the relative **ROTATING TOUCHER** and using the code that you will find in the price list.

6.2. INSTRUCTIONS FOR USE OF THE WHEELS - GRINDING TO POLISHING STAGES OF TOROIDAL PROFILES ON MARBLE - WITH THE MASTER 3500

! WARNING!!! Before starting to work with your **MASTER 3500** please check that the rotating direction of the spindle corresponds to the indications on the machine; if otherwise, please invert two of the three wires in the plug.

Furthermore, the operator must not change the position of the spindle between one sequence and the next once the spindle has been positioned correctly for the **POS. 1** tool; this would deform the **LONGLIFE** wheels (polishing wheels).

If this is done, **MARMOELETROMECCANICA**, will not cover any damages. Finally, we would like to remind you that the **LONGLIFE** polishing wheels need to be run in for a short period; for this it is advisable to use a metre of waste material to do this.

! WARNING!!! IT IS FORBIDDEN to use dirty water with the **LONGLIFE** tools. Before starting work, check that the water supply has a filter which will keep the water clean.

POSITION 1 - ELETTROLYTIC

GREEN Diamond grinding wheel with **ROTATING TOUCHER**:

Set the RPM switch at 6000. Move the machine towards the slab and press against it slightly. Move the machine a few centimetres both to the left and then to the right until the wheel itself idles: this means that the rotating toucher has touched the slab and at that stage, the first phase has been completed.



POSITION 2 - ELETTROLYTIC

BRONZE Diamond grinding wheel with ROTATING TOUCHER

Continue at 6000 rpm by using the same care as for the Position number 1; this phase of operation is terminated when the rotating toucher touches the slab and the wheel is idle; after using Position 2 you will be able to see that the waves or irregularities left over from the Position 1 have disappeared and that the profile is homogenous.

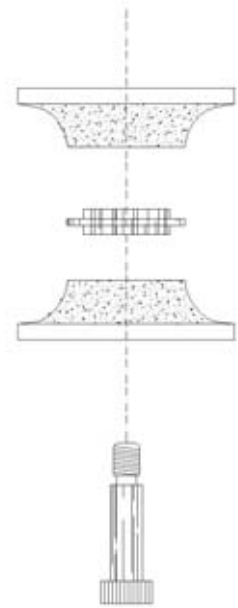

POSITION 3 - BIPOWER

The Pos. 3 **BIPOWER** wheel will both rectify the profile and prepare it for the polishing phase. It is used by moving it from left to right and viceversa a minimum of 2/6 times at 6000 rpm, depending on the thickness of the slab and on how detailed the profile shape is. We recommend that you make quick, constant passes giving a little push but avoiding any breaks in the operation so that there are no undulations.

N.B.: When Pos. 3 **BIPOWER** has already been used to complete quite a number of metres, it will be necessary to do a few extra passes in order to obtain a perfect profile.

POSITION 4 (4 extra) - LONGLIFE

Pass this wheel at 3000 rpm – make from minimum 4 passes to a maximum of 6 passes from left to right and viceversa pushing a little. Avoid any breaks during the operation in order to avoid any undulations.

POSITION 5 (5 extra) - LONGLIFE

Pass this wheel at 3000 rpm – make from a minimum of 6 passes to a maximum of 8 passes from left to right and viceversa pushing a little.

POSITION 6 (6 extra) - LONGLIFE

Pass this wheel at 3000 rpm – make from a minimum of 8 passes to a maximum of 12 passes from left to right and viceversa pushing a little.

NB: THE NUMBER OF PASSES THAT ARE REQUIRED MAY DEPEND ON THE MATERIAL, THE CLIENT'S REQUIREMENTS AND THE STATE OF WEAR OF THE WHEEL ITSELF.

POLYPASTE BOTTLE

POLYPASTE is a highly-concentrated solution (type of wax) of chemical polishing components, which easily remove the opaque layer left by atmospheric agents. It is particularly indicated to be used after the traditional polishing systems. Put **POLYPASTE** on a wool cloth, polish the slab till complete drying of the paste.

The **ZENITH/CROMOLINE POS.1 BLUE** wheels with **ROTATING TOUCHER** can be transformed into the following different profiles by simply changing the **ROTATING TOUCHER** (*n.b.: pos. 2 cannot be transformed*):

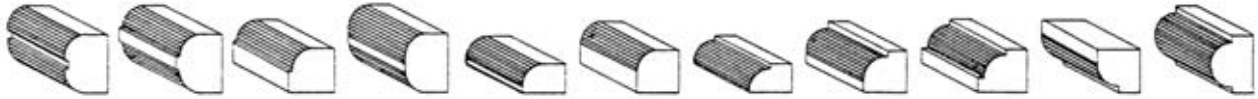

WARNING!!! Such transformations can be made only on the **POSITION 1** grinding wheels, by simply ordering the relative **ROTATING TOUCHER** and using the code that you will find in the price list.

SECTION 7: SAFETY

OIL WATER SYSTEM

1. IDENTIFICATION

BRAND NAME:	OIL WATER SYSTEM
FUNCTION:	PROTECTION FOR WATER SYSTEM PLATE
SUPPLIER:	MARMOELETTROMECCANICA S.r.l. Via Flaminia Km 41,400 00068 Rignano Flaminio (Roma) - ITALY Tel. +39 0761-50.51 - Fax +39 0761-50.83.88

2. COMPOSITION/INFORMATION ON INGREDIENTS

Substances of dangerous content, as per DM dated 28.4.97

Aqueous emulsion of polydimethylsiloxane with aminoalchilic groups

Non classified EEC product

SYMBOL: Xi Irritant

R-phrases R36 Irritating to eyes

Concentration in product < 10% (Non scheduled symbol, non scheduled R-phrases)

3. IDENTIFICATION OF DANGER

The following information refers to this product as it stands. Observe usual standard norms of good practice in industry to ensure safe use of product.

4. FIRST AID MEASURES

SKIN CONTACT: wash with soap and water.

EYE CONTACT: wash immediately with running water for at least 15 minutes. If irritation should persist, consult your doctor.



IF INGESTED: if the harmed party is conscious, make them vomit. Consult a doctor immediately.

IF INHALED: the product does not emit irritating or harmful vapours if used correctly.

5. FIREPROOFING MEASURES

DANGER OF FIRE: the product is not flammable. In case of fire, cool down the containers exposed to it.

EXTINGUISHING AGENTS: CO₂, foam, atomised/spray water.

DO NOT USE: -----

PROTECTIVE EQUIPMENT: no specific protective measures required.

COMBUSTION PRODUCTS: CO_x, SiO₂.

6. MEASURES TO BE TAKEN IN CASE OF INCIDENTAL RELEASE

INDIVIDUAL PRECAUTIONS: no specific precautions required.

ENVIRONMENTAL PRECAUTIONS: avoid discharge into waterways and drains.

CLEANING METHODS: absorb by using cloths, sand, fossil meal. Wash with abundant water.

7. MANIPULATION AND STOCKING

MANIPULATION: while pouring avoid any bubbling which might cause incidental sprays/spillage.

STOCKING: keep in hermetically sealed containers. Protect from frost



8. EXPOSURE CONTROL/INDIVIDUAL PROTECTION

PRECAUTIONS:	none in particular.
RESPIRATORY PROTECTION:	not necessary.
EYE PROTECTION:	use protective goggles while pouring.
SKIN PROTECTION:	use normal working attire.
HAND PROTECTION:	use rubber or PVC gloves.

9. PHYSICOCHEMICAL CHARACTERISTICS

APPEARANCE AT 20 °C:	milk white liquid
SMELL:	odourless
pH:	8
pH sol. 1%:	7.5
BOILING POINT:	100° C
IGNITION POINT:	fireproof
AUTO IGNITION:	-----
EXPLOSIVE PROPERTIES:	non-explosive
VAPOUR PRESSURE:	not available
DENSITY AT 20° C:	1 Kg/dm ³
WATER SOLUBLE PROPERTIES:	complete
FAT SOLUBLE PROPERTIES:	insoluble
VAPOUR DENSITY:	not available

10. STABILITY AND REACTIVITY

CONDITIONS TO AVOID:	do not expose to temperatures lower than 0° C. for prolonged periods of time.
SUBSTANCES TO AVOID:	strong acids, strong oxidants.
PRODUCTS OF DANGEROUS DECOMPOSITION	measurements carried out at temperatures higher than 150° C show that small quantities of formaldehyde separate themselves via incomplete oxidating decomposition.



11. TOXICOLOGY INFORMATION

EFFECTS ON MAN:	none we are aware of.
EFFECT ON EYES:	may cause irritation.
EFFECT ON SKIN:	if contact is repeated and prolonged, it may cause irritation to particularly hazardous subjects.
EFFECT IF INGESTED:	practically non-toxic LD 50 > 5000 mg/kg.
EXPOSURE PATHWAYS:	cutaneous, ingestion.

12. ECOLOGICAL INFORMATION

Use according to good practice; avoid dispersing the product in the environment, see points 3, 6 and 13.

13. WASTE DISPOSAL CONSIDERATIONS

Dispose of any excesses, waste and empty containers according to all relevant local and national regulations.

14. REGULATION INFORMATION

LABELLING AS PER DM 28.4.97

SYMBOL:	not required.
R-phrases:	not required.
S-phrases	not required.
DANGEROUS COMPONENTS:	-----

15. OTHER INFORMATION

Product to be used exclusively for professional purposes. This information should be made readily available to all workers who have to use this product for professional purposes.

The information and recommendations outlined here are based on the knowledge to date. They refer exclusively to the product in question and they do not constitute any form of guarantee of particular quality. The user must ensure suitability and completeness of such information in relation to the specific use that he must make of it.

This chart substitutes all previous editions.



POLYPASTE

1. IDENTIFICATION

BRAND NAME: **POLYPASTE**

FUNCTION: CERA LUCIDANTE PER MARMI E GRANITO

SUPPLIER: MARMOELETTROMECCANICA S.r.l.
Via Flaminia Km 41,400
00068 Rignano Flaminio (Roma) - ITALY
Tel. +39 **0761-50.51** - Fax +39 **0761-50.83.88**

2. COMPOSITION/INFORMATION ON INGREDIENTS

Natural waxes

Solvents

3. IDENTIFICATION OF DANGER

The product is flammable if placed close to a source of ignition heat.

4. FIRST AID MEASURES

SKIN CONTACT: wash with abundant soap and water.

EYE CONTACT: wash immediately with running water for at least 10 minutes and consult your doctor.

IF INGESTED: visit the doctor and show him the safety card

IF INHALED: the product does not emit irritating or harmful vapours if used correctly.



5. FIREPROOFING MEASURES

This product may generate inflammable mixtures or burn only if heated to a temperature that is equal to or higher than inflammability.

RECOMMENDED EXTINGUISHING AGENTS: water, foam, chemical powders depending on the materials involved in the fire. Spray the fire with water.

FORBIDDEN EXTINGUISHING AGENTS: none in particular

COMBUSTION RISK: avoid inhaling the fumes

PROTECTIVE EQUIPMENT: use equipment to protect respiratory tract

6. MEASURES TO BE TAKEN IN CASE OF INCIDENTAL RELEASE

INDIVIDUAL PRECAUTIONS: no specific precautions required.

ENVIRONMENTAL PRECAUTIONS: no specific precautions required.

CLEANING METHODS: no specific precautions required.

7. HANDLING AND STOCKING

HANDLING: avoid skin contact. While working do not eat or drink.

STOCKING: keep containers well sealed, store in well aired environment

8. EXPOSURE CONTROL/INDIVIDUAL PROTECTION

PRECAUTIONARY MEASURES: work in well-aired environment or where there is an adequate system of ventilation.

RESPIRATORY PROTECTION: no particular precaution necessary when used in a normal way.

EYE PROTECTION:	use protective goggles when product may be close to eyes.
SKIN PROTECTION:	use normal working attire.
HAND PROTECTION:	use protective gloves.

9. PHYSICOCHEMICAL CHARACTERISTICS

APPEARANCE:	white and/or black solid
SMELL:	fragrant
IGNITION POINT:	approx. 45° C
AUTO IGNITION:	> 200° C
DENSITY AT 20° C:	1.2
WATER SOLUBLE PROPERTIES:	insoluble

10. STABILITY AND REACTIVITY

CONDITIONS TO AVOID:	this product is stable when used under normal circumstances
SUBSTANCES TO AVOID:	none in particular

11. TOXICOLOGY INFORMATION

EFFECT ON EYES:	may cause irritation if it comes into contact with the eyes.
EFFECT ON SKIN:	if contact is repeated and prolonged, it may cause irritation to the skin.
EFFECT IF INHALED:	high concentration of vapour may cause headaches.
EXPOSURE PATHWAYS:	inhalatory and cutaneous.

12. ECOLOGICAL INFORMATION

Use according to good practice; avoid dispersing the product in the environment.

13. WASTE DISPOSAL CONSIDERATIONS

Dispose of any excesses, waste and empty containers according to all relevant local and national regulations.

14. TRANSPORT INFORMATION

Road and ferry transport (adr/rid): class: 3

Classification code: f1

Onu adr_number: 1299

Adr_packing_group: II°

Sea transport (imdg/imo): 3.2

Imdg: onu_number: 1299

Imdg_packing_group: II°

Transport emergency card: 30g35

15. REGULATION INFORMATION

DM 28.1.92 (Classification and labelling)

SYMBOLS:



R-phrases:

R 10 Flammable.

R 21 Harmful in contact with skin.

R 22 Harmful if swallowed.

S-phrases:

S 15 Keep away from heat.

S 20 When using do not eat or drink.

S 44 If you feel unwell, seek medical advice immediately.



16. OTHER INFORMATION

Product to be used exclusively for professional purposes. This information should be made readily available to all workers who have to use this product for professional purposes.

The information and recommendations outlined here are based on the knowledge to date. They refer exclusively to the product in question and they do not constitute any form of guarantee of particular quality. The user must ensure suitability and completeness of such information in relation to the specific use that he must make of it.

This chart substitutes all previous editions.

marmoelettromeccanica 

UTENSILI DIAMANTI • DIAMOND TOOLS • OUTILS DIAMANTS • UTENSÍLIOS DIAMANTADOS • DIAMANTWERKZEUGE

00068 Rignano Fl. (Rm) - Italy • Via Flaminia Km 41,400
Tel.: +39 0761 50.51 • Fax: +39 0761 50.83.88 • info@marmoelettro.it • www.marmoelettro.it